

Bariatric Ceiling Lift



Lifts up to 1000 lbs.

Featuring a single motor and single track, the Medicare Bariatric Ceiling Lift 1000 has a weight capacity up to 1000 lbs., allowing flexibility in the type of patient that can be transferred. Ideal for bariatric wards or rooms designated for the bariatric population. Medicare Ceiling Lifts are manufactured in the United States. Medicare's assortment of track options and components allow installation in a variety of room and building styles.

Item Number:

700100 – Bariatric Ceiling Lift - lifts up to 1000 lbs.

Features:

- *Digital display time meter*
- *Manual traversing*
- *Return to charge*
- *Visual/audible low battery indicator*
- *Emergency lowering system*
- *Built-in safety stops*
- *Electric hand control*
- *Scale option*
- *Automatic battery conservation*
- *Soft start/stop for comfort*
- *Heavy duty batteries for more lifts*
- *Efficient battery charge cycle*
- *2 year warranty*

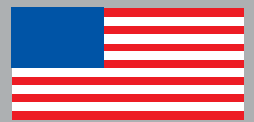

MADE IN THE USA



Medcare Bariatric Ceiling Lift 1000

Model #700100 – lifts up to 1000 lbs.

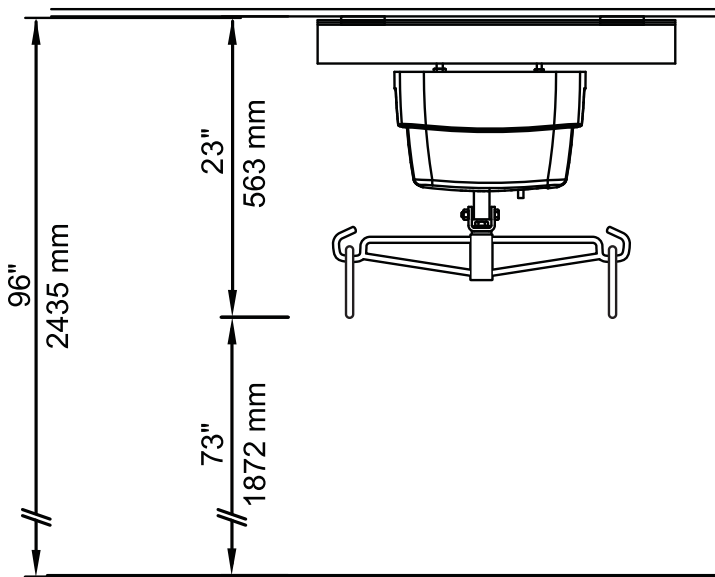

Technical Specifications

Lift Motor:	24 VDC (All models)	Lift Case:	Flame Retardant ABS
Traverse Motor:	24 VDC (Optional at time of purchase)	Hand Control:	Sealed Electric Membrane Switch
XY Traverse Motors:	24 VDC (Optional at time of purchase)	Lifting Height:	Up to 92"
Transcord System:	(Optional at time of purchase)	Hoist Weight:	48 lbs.
Charger Input:	110 VAC, 1.0 Amps	Maximum Load:	1000 lbs.
Charger Output:	24 VDC, 1.5 Amps	Warranty:	Two Years (excludes batteries)
Batteries:	24 VDC (2 x 12 VDC), 7.0 AH		

Med
HANDLE WITH CARE.

Hanger Bar Stopper Option

The Medcare Hanger Bar Stopper prevents sling loops from sliding off of the hanger bar hooks.



Item Number:
400611

PRODUCT HIGHLIGHTS

- Digital display running time meter along with audio and visual battery life indicator



- 92" lifting range allows lifting from the floor and over high thresholds
- The slack strap sensor ensures the lift strap will not continue to unwind if weight distribution is not even.
- Manual lowering in the absence of power
- 4-point, non-rigid hanger bar design allows sling to conform to patient for added comfort
- Microban® antimicrobial product protection featured on padding and strap.



Medcare Products

151 East Cliff Road
Burnsville, MN 55337
Toll-free: 800-695-4479
Fax: 952-894-7153
www.medcarelifts.com

© 2009 Medcare Products Inc.
Specifications are subject to change without notice. All products referred herein are registered trademarks or trademarks of their respective holders. MICROBAN is a registered trademark of Microban Products Company.